

Collared Eyebolts Metric Thread

TO BS 4278 TABLE 1

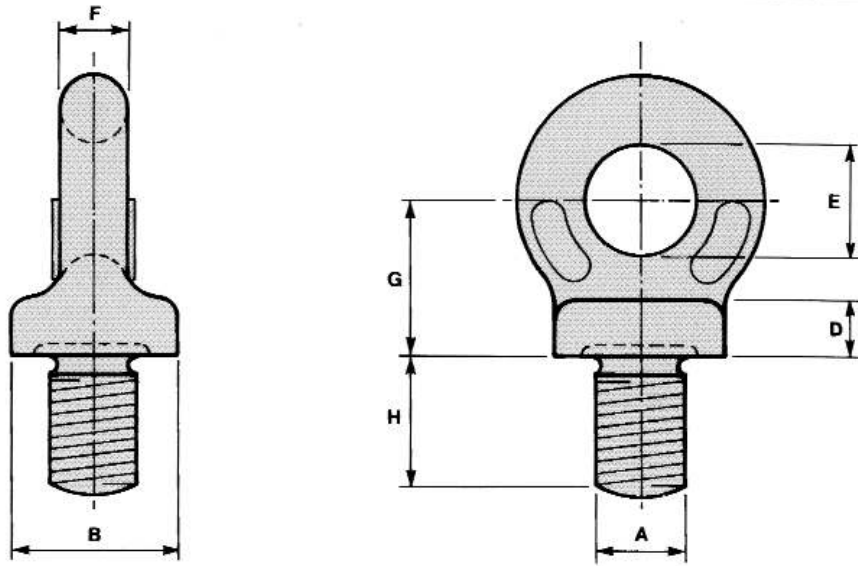

A	B	D	E	F	G	H	SWL 1968	SWL 1984	Weight Each
mm	mm	mm	mm	mm	mm	mm	tonnes	tonnes	kgs
M8	22	7	15	9	20	18	0.15	---	0.06
M10	22	7	15	9	20	18	0.25	---	0.07
M12	22	7	15	9	20	18	0.32	0.40	0.07
M14	29	10	20	12	26	23	0.50	---	0.15
M16	29	10	20	12	26	23	0.63	0.80	0.16
M18	36	12	24	14	32	28	1.00	---	0.28
M20	40	14	27	16	36	32	1.25	1.60	0.44
M22	45	15	30	18	40	35	1.60	---	0.56
M24	52	17	35	21	46	40	2.00	2.50	0.84
M27	58	20	39	23	52	46	2.50	---	1.14
M30	65	22	44	26	58	51	3.20	4.00	1.66
M33	72	24	48	29	64	56	4.00	---	2.24
M36	81	27	54	32	72	63	5.00	6.30	3.17
M39	90	30	60	36	80	70	6.30	---	3.92
M42	90	30	60	36	80	70	7.00	8.00	3.92
M45	101	34	68	40	90	79	8.00	---	6.00
M48	101	34	68	40	90	79	9.00	10.00	6.00
M52	115	38	76	46	102	89	10.00	12.50	9.00
M56	128	43	86	51	114	100	12.50	16.00	13.00
M64	144	48	96	58	128	112	16.00	20.00	17.50
M70	172	54	108	65	144	126	20.00	---	31.00
M72	172	54	108	65	144	126	22.00	25.00	31.00
M76	172	54	108	65	144	126	25.00	---	31.00

**BFE
19**

© Brooks Forgings Ltd 2008

SPECIFICATIONS AVAILABLE

MATERIAL

BS970 080A27 (EN5A)
STAINLESS STEELS
ALLOY STEELS
B7

**SWL IS SHOWN FOR VERTICAL LIFT
LONGER SHANK AVAILABLE UPON REQUEST**

FINISH

SELF COLOUR
GALVANISED
ELECTROPLATED
CHEMICAL BLACK
PTFE COATING